

# ELANTRAC<sup>®</sup>



0306 - ISS 2

## EARTH BORERS

Model Nos: ED120 & ED160

Part Nos: 3400950 & 3400960

## OPERATING & MAINTENANCE INSTRUCTIONS

# Clarke<sup>®</sup>

INTERNATIONAL



When using this machine, ALWAYS use BOTH hands, using a firm grasp, adopting a firm stance, with legs wide apart and slightly bent.

## Spare Parts & Servicing Contacts

For Spare Parts and Service, please contact your nearest dealer, or CLARKE International, on one of the following numbers.

**PARTS & SERVICE TEL: 020 8988 7400**

**PARTS & SERVICE FAX: 020 8558 3622**

or e-mail as follows:

**PARTS: [Parts@clarkeinternational.com](mailto:Parts@clarkeinternational.com)**

**SERVICE: [Service@clarkeinternational.com](mailto:Service@clarkeinternational.com)**

Thank you for purchasing this Clarke Hole Boring machine, designed for boring holes in soil only, for fence posts, reforestation, and similar operations.

**Before operating this machine, you should thoroughly familiarise yourself with all aspects of its' operation, and follow all instructions in this manual.** In doing so you will ensure the safety of yourself and that of others around you, and with correct handling and servicing, you can look forward to the borer giving you long and satisfactory service.

## GUARANTEE

This CLARKE product is guaranteed against faulty manufacture for a period of 12 months from the date of purchase. Please keep your receipt which will be required as proof of purchase.

This guarantee is invalid if the product is found to have been abused or tampered with in any way, or not used for the purpose for which it was intended.

Faulty goods should be returned to their place of purchase. No product can be returned to us without prior permission.

This guarantee does not effect your statutory rights.

## Contents

<b>Parts and Service contacts</b> .....	<b>2</b>
<b>Safety Precautions</b> .....	<b>4</b>
<b>Overview</b> .....	<b>5</b>
<b>Assembly Instructions</b> .....	<b>5</b>
<b>Operation</b>	
<b>Filling with Fuel</b> .....	<b>7</b>
<b>Controls</b> .....	<b>7</b>
<b>Cold Starting</b> .....	<b>8</b>
<b>Decompression</b> .....	<b>8</b>
<b>Maintenance</b> .....	<b>9</b>
<b>Fault Finding</b> .....	<b>10</b>
<b>Spare Parts</b> .....	<b>11</b>
<b>Accessories</b> .....	<b>11</b>
<b>Specifications</b> .....	<b>11</b>

# SAFETY PRECAUTIONS

## WARNING

*As with all machinery, there are certain hazards involved with their operation and use. Exercising respect and caution will considerably lessen the risk of personal injury. However, if normal safety precautions are overlooked, or ignored, personal injury to the operator, or damage to property may result.*

- X NEVER** allow children, or those physically incapable, of handling this machine, as it may vibrate considerably, and its handling will require a degree of physical exertion.
- X NEVER** use this machine for boring in landfill or soil known to contain rocks or debris.
- X NEVER** operate this machine whilst under the influence of alcohol or drugs, or any medication.
- X NEVER** start the engine in confined spaces.
- X NEVER** make any adjustment or perform a service operation with the engine running.
- X NEVER** operate an engine driven unit in an explosive atmosphere, near combustible materials, or where there is insufficient ventilation.
- X NEVER** refuel the engine whilst it is running, and allow the engine to cool sufficiently before refuelling. Use ONLY recommended 2-stroke mixture. (See 'Specifications', p11)
- ✓ ALWAYS** observe all safety precautions for the handling of fuel.
- ✓ ALWAYS** use replacement parts supplied by the manufacturer. The use of non standard parts could be hazardous.
- ✓ ALWAYS** wear appropriate clothing...strong working boots, overalls...ensuring there are no loose items which could snag, industrial type gloves, and a helmet.
- ✓ ALWAYS** wear Ear Defenders/Protection and Safety goggles, manufactured to the latest European standards.
- ✓ ALWAYS** be alert and adopt a firm stance when handling the machine. Be prepared for the machine to jarr suddenly should the auger come into contact with a submerged or heavy object, heavy clay or tree roots etc.
- ✓ ALWAYS** check to ensure the Auger securing bolts are tight before each use.
- ✓ ALWAYS** use BOTH hands to control the machine.
- ✓ ALWAYS** check, before use, to ensure there are no submerged drains, pipes, culverts etc., that may interfere with the boring operation.
- ✓ ALWAYS** keep bystanders well clear of the boring operation.

# OVERVIEW

The Earth Borer comprises two major components.....the drive mechanism, or engine and gearbox, and an Auger. Three sizes of Auger are available from Clarke International, as follows:

<b>Model</b>	<b>EDA100</b>	<b>which has a length of</b>	<b>800mm</b>	<b>and a diameter of</b>	<b>100mm</b>
“	<b>EDA150</b>	“	<b>800mm</b>	“	<b>150mm</b>
“	<b>EDA200</b>	“	<b>800mm</b>	“	<b>200mm</b>

Additionally an Extension Piece is available, with a length of 400mm

**See Accessories on page 10, or your Clarke dealer for details.**

The machine is designed for one man operation, but some exertion may be necessary, due to the forces involved, the quality or type of soil being worked and the uncertainty of what lies below the surface.

Extreme care must therefore be exercised when using the machine, as it may lurch suddenly if, for example it comes into contact with strong tree roots or grabs on dense clay etc. All of these possibilities should be taken into account.

# ASSEMBLY

Remove the components from the packing, and inspect for signs of damage which may have occurred during transit. Should any damage be apparent, please inform your Clarke dealer immediately.

One carton contains the Auger attachment, the other contains the following components:

- A. The Motor assembly complete
- B. The Handle complete with the throttle controls
- C. A Wallet containing the items shown in fig. 1. These are:

- 1. 1 x double ended screwdriver set. (1 x crosshead, 1 x flat)
- 2. 2 x Hex. wrenches
- 3. 1 x Double end Hex. socket
- 4. 3 x Hex. head socket screws with spring washers
- 5. 2 x Hex. Screws with nuts and spring washers.

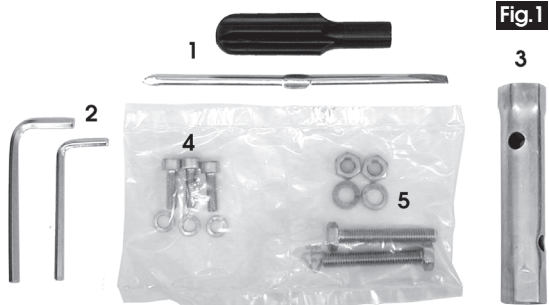

**Fig.1**

It is necessary to attach the handle, throttle controls and the Auger attachment, as follows:

1. Rest the engine assembly on a workbench or table, with the handle lying alongside, ensuring it is the right way up.
2. Take the throttle cable and thread it through the opening in the underside of the motor housing, as shown in Fig. 2.
3. Locate the Nipple, on the end of the cable, in the depression in the end of the swivel block on the throttle lever, arrowed in Fig.2, then, ensuring the cable is positioned so that it lies in the curved guide provided, grasp the outer sheath, using the knurled ring adjacent to the threaded end, and pull, against spring pressure, so that the threaded end of the outer sheath butts up against the end of the guide.

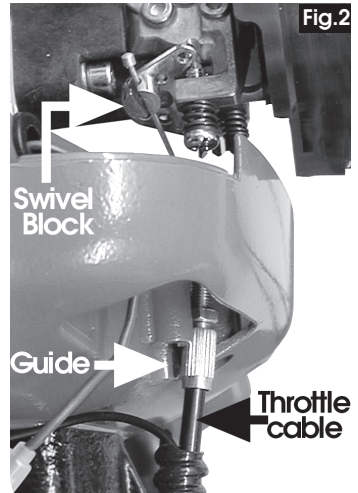

You will note that the end of the guide is threaded internally. Proceed to screw the threaded end of the sheath into the guide until all tension is removed from the inner cable. i.e. the throttle is fully closed.

Screw out again until the position is found where tension is just beginning to be taken. At this point, screw up the lock nut (A, Fig. 3) and tighten, but not before sliding the earth terminal (C, Fig. 3), between the housing and the nut, as shown in FIG. 3a .

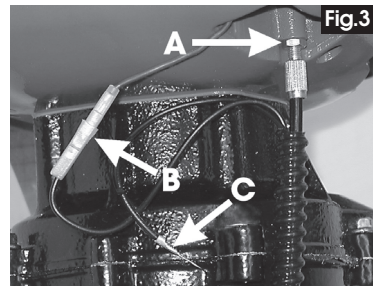

**NOTE: Fig.2 shows the throttle components with the engine cover removed. It is not necessary for the cover to be removed to perform the above operation.**

4. Connect the spade connector shown at 'B', Fig. 3, ensuring the protective cover is firmly in place.
5. Attach the handle using the three Hex. socket head screws and washers provided, noting that the handle will fit in one position only.
6. Bolt the selected auger on to the output shaft using the nuts, bolts and spring washers supplied (see Fig. 4), ensuring the nuts are tight. ALWAYS make this check before each use.

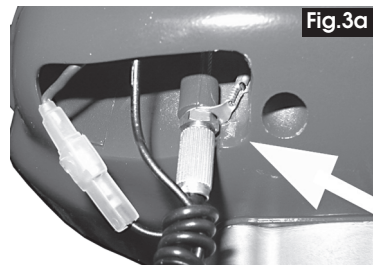

# OPERATION

## Filling with Fuel

These engines run on a 2-stroke mix as follows:

- a. 20 Parts Petrol to 1 Part 2-Stroke MINERAL oil.....or
- b. 50 Parts Petrol to 1 Part 2-Stroke SYNTHETIC 2-Stroke oil.

**Petrol may be either Unleaded or 4 Star.**

Mix the fuel in a separate container in a well ventilated area, away from naked flame. Observe all precautions for handling fuel. NO SMOKING etc.

Unscrew the fuel tank filler cap, and fill the tank to one inch below the filler neck using a funnel. Wipe away any spillage thoroughly, replace the cap on the fuel container and move the container a safe distance away.

### WARNING!

**NEVER** refill the fuel tank when the engine is hot....**ALWAYS** wait until it has cooled down sufficiently.

## Controls

The control handle, shown opposite, comprises three major components.

1. The Safety Lever
2. The Throttle Lever, and
3. The Stop/Start Switch.

The Stop/Start Switch has three positions.....**STOP**.....**MID**.....**START**.

1. Lay the Borer, with Auger attached, on its side with pull rope facing upwards.
2. Place the **Stop/Start** Switch in its **MID** position.
3. Press the **Safety Lever** down whilst pulling the **Throttle Lever** UP with the fingers - fully.
4. Place the **STOP/START** Switch in its **START** position, and release the Throttle and Safety Levers. The Throttle is now set so that the engine will run at a fast idle.
5. Grasp the pull rope and pull sharply. The engine should start within 2 or 3 pulls.

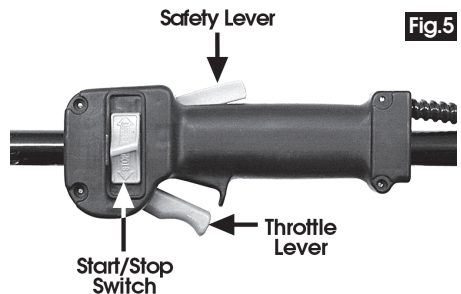

Fig.5

### WARNING!

**Be aware that when the engine starts, the Auger will rotate. Ensure that nothing can snag or become caught up in the spinning helix.**

#### NOTE:

1. For Cold Starting, see notes below.
2. Model ED160 is provided with a decompression device for easy starting - see notes below.

Once started, allow to run for short period in order for the engine to warm up, then blip the throttle briefly using the throttle lever. The STOP/START Switch will automatically revert to its MID position and the engine will idle. The Auger should stop rotating at Idle speed, allowing the machine to be raised and moved over the desired boring point.

**In order to operate the throttle once more....it will be necessary to depress the SAFETY LEVER FIRST. NEVER force the throttle as it will be in a locked state.**

Depress the safety lever with the palm of the hand whilst pulling up the throttle lever with the fingers. Increasing engine speed will cause the auger to rotate....the faster the speed, the faster the rotation.

To STOP the engine, place the STOP/START Lever in the STOP position.

## Cold Starting

In cold conditions, the choke may be used to aid starting.

Before attempting to start, move the Choke Control Lever towards the CLOSED position as shown in the illustration opposite. You may set the lever to fully or partially closed, depending upon conditions.

Set the controls as previously described, and pull the Pull Rope sharply.

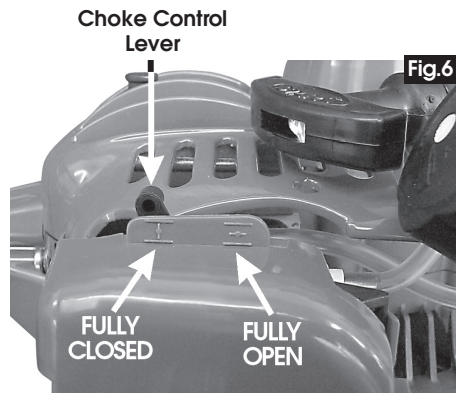

Once the engine has started move the Choke Control Lever towards the OPEN position so that the engine runs as smoothly as possible. Allow to run for a short period so that the engine warms, gradually moving the Choke to the OPEN position.

## Decompressor

### Model ES 160 ONLY

The decompressor device provides for easy starting. The Decompressor Knob is located on top of the cylinder block, shown in the illustration opposite.

Before attempting to start, push the knob DOWN fully. As soon as the engine starts, the knob will automatically reset.

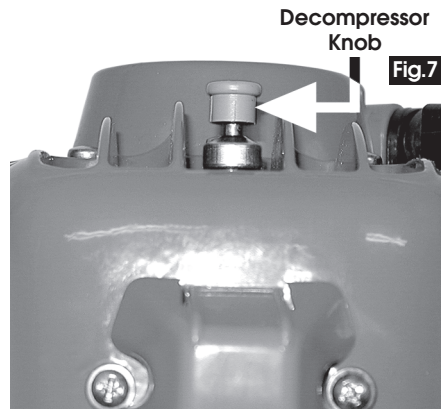



# Maintenance

## Before each Use

Check the security of the Auger. Ensure the securing nuts are tight.

Check for fuel leaks and rectify before use.

Check for any apparent damage and rectify before use or consult your Clarke dealer.

## Every 25 Hours of Use

### A. SPARK PLUG

Remove spark plug, clean and set gap to 0.5mm.

To gain access to the spark plug, remove the cover, shown in the illustration opposite by pressing down on tab 'A'. The cover may then be pulled off

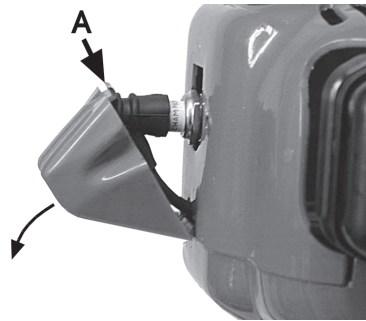

Fig.8

### B. AIR FILTER

The Air Filter cover is secured by two plastic locking tabs - one each side and shown in the illustration opposite. Press one of these tabs inwards, using a suitable tool, whilst pulling the cover upwards.

Remove the sponge filter and wash in warm soapy water. Rinse thoroughly and ensure it is thoroughly dry before replacing.

Clean the cover and the housing, which is still attached to the carburettor.

Take great care NOT to allow foreign bodies to enter the carburettor intake. Moving the choke control lever to the CLOSED position, to close off the air intake, will assist in this matter.

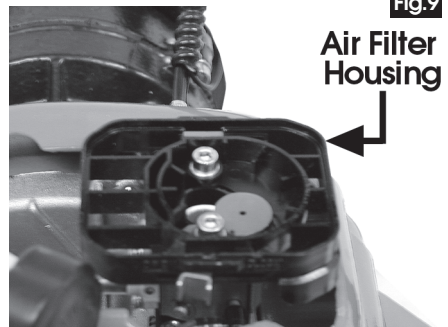

Fig.9

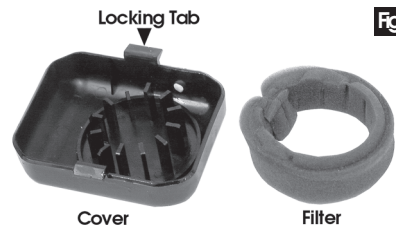

Fig.10

## Every 50 Hours of USE

The machine should be serviced by a qualified technician. Please contact your Clarke dealer for advice.

## Storage

If you do not expect to use the machine for some time, then the following tasks should be undertaken before storing.

1. Empty the fuel tank completely, then start the engine and allow to run until it stops for lack of fuel. Ensure the fuel cap is replaced and is secure.
2. Remove the spark plug (see page 8) and pour into the cylinder chamber several drops of 2-stroke oil.
3. Crank the engine slowly, using the pull rope, in order to distribute oil around the cylinder and piston, then replace the spark plug.
4. Carefully clean all parts, ensuring a film of oil covers bare metal parts...Use a brush to clean the cooling fins. Oil the throttle linkage at the carburettor.
5. Store in a dry environment, in a shed or garage etc., preferably covered.

## Fault Finding

In the event that you find difficulty in starting, or there is lack of power, it is likely that the problem lies with either carburation or ignition. The following checks will help to diagnose the problem.

1. Check to ensure the fuel tank has sufficient fuel mixed at the correct ratio.
2. Check to ensure there is no water contamination of the fuel. If necessary, drain the fuel tank and refill.
3. Check fuel line from tank to carburettor...it may be clogged.
4. Check Fuel Cap....Remove cap then replace loosely...if the engine starts, it is likely that the fuel cap breather is clogged or damaged. Replace if necessary.
5. Air Filter may be clogged.
6. Spark plug may be dirty or gap is excessive....clean and have it tested.
7. Possible ignition fault...check for spark by removing spark plug, and with lead attached, crank the engine with metal part of the plug held against bare metal. **DO NOT UNDER ANY CIRCUMSTANCES TOUCH THE METAL PART OF THE PLUG.** The spark plug must be known to be in good condition.
8. The 'STOP' button wire may be broken or become disconnected, creating a permanent STOP condition.

Should these checks not solve the problem...consult your Clarke dealer.

## Spare Parts

User serviceable spare parts are as follows:

<b>Fuel Cap</b>	<b>Part No.</b>	<b>723730</b>
<b>Air Filter element</b>	<b>Part No.</b>	<b>331040</b>
<b>Spark Plug</b>	<b>Part No.</b>	<b>450730</b>

For all repairs and servicing...consult your Clarke dealer

## Accessories

<b>Auger 100mm dia x 800mm</b>	<b>Model EDA100</b>	<b>Part No. 3400991</b>
<b>Auger 150mm dia x 800mm</b>	<b>Model EDA150</b>	<b>Part No. 3400993</b>
<b>Auger 200mm dia x 800mm</b>	<b>Model EDA200</b>	<b>Part No. 3400995</b>
<b>Extension Piece</b>	<b>Model EDE400</b>	<b>Part No. 3400990</b>

## Specifications

	<b>ED120</b>	<b>ED160</b>
<b>Engine Type</b>	2-Stroke	2-Stroke
<b>Capacity</b>	39cc	52cc
<b>Output</b>	1.8HP	2.6HP
<b>RPM</b>	7000	7000
<b>Fuel capacity</b>	0.9ltrs	0.9ltrs
<b>Fuel Mix</b>	20:1	20:1
<b>Carburettor</b>	Diaphragm	Diaphragm
<b>Spark Plug</b>	Champion RCJ8	Champion RCJ8
<b>Ignition System</b>	Electronic	Electronic
<b>Starter Type</b>	Recoil	Recoil
<b>Max. Drilling Diameter</b>	220mm	220mm
<b>Clutch</b>	Auto Centrifugal	Auto Centrifugal
<b>Gearbox Lubrication</b>	Grease	Grease
<b>Vibration (aw)</b>	Less than 2.5 m/s <sup>2</sup>	Less than 2.5 m/s <sup>2</sup>
<b>Output Revs(Auger RPM)</b>	160 - 200RPM	160 - 200RPM
<b>Dimensions</b>	430x700x430mm	430x700x430mm
<b>Weight</b>	10.5kg	10.5kg
<b>Part No.</b>	3400950	3400960

# A SELECTION FROM THE VAST RANGE OF

# Clarke®

## QUALITY PRODUCTS

### AIR COMPRESSORS

From DIY to industrial, Plus air tools, spray guns and accessories.

### GENERATORS

Prime duty or emergency standby for business, home and leisure.

### POWER WASHERS

Hot and cold, electric and engine driven - we have what you need

### WELDERS

Mig, Arc, Tig and Spot. From DIY to auto/industrial.

### METALWORKING

Drills, grinders and saws for DIY and professional use.

### WOODWORKING

Saws, sanders, lathes, mortisers and dust extraction.

### HYDRAULICS

Cranes, body repair kits, transmission jacks for all types of workshop use.

### WATER PUMPS

Submersible, electric and engine driven for DIY, agriculture and industry.

### POWERTOOLS

Angle grinders, cordless drill sets, saws and sanders.

### STARTERS/CHARGERS

All sizes for car and commercial use.

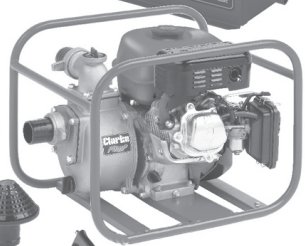
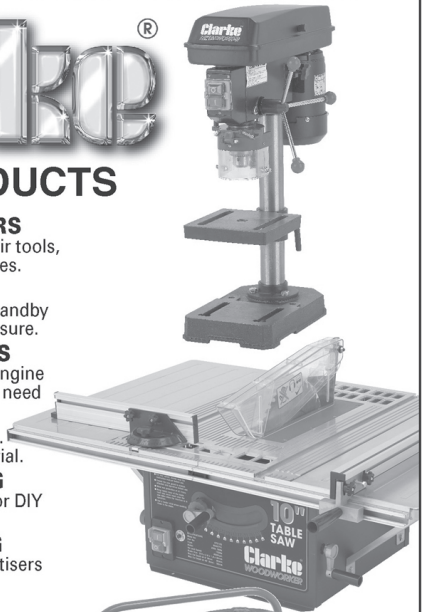

**PARTS & SERVICE: 0208 988 7400**  
E-mail: [Parts@clarkeinternational.com](mailto:Parts@clarkeinternational.com) or [Service@clarkeinternational.com](mailto:Service@clarkeinternational.com)  
**SALES: UK 01992 565333 or Export 00 44 (0)1992 565335**

**Clarke® INTERNATIONAL** Hemnall Street, Epping, Essex CM16 4LG  
[www.clarkeinternational.com](http://www.clarkeinternational.com)